

Support System for Fall Protection During Gait Studies

Preliminary Report

**Mark Rubalcava
Adrian Rodriguez
Jack Olsen
Andrew Strelow**

2017



Project Sponsor: Zach Lerner, Ph.D., Director of NAU's Biomechatronics Lab
Faculty Advisor: Dr. Jennifer Wade
Sponsor Mentor: Dr. Zach Lerner
Instructor: Dr. Jennifer Wade

DISCLAIMER

This report was prepared by students as part of a university course requirement. While considerable effort has been put into the project, it is not the work of licensed engineers and has not undergone the extensive verification that is common in the profession. The information, data, conclusions, and content of this report should not be relied on or utilized without thorough, independent testing and verification. University faculty members may have been associated with this project as advisors, sponsors, or course instructors, but as such they are not responsible for the accuracy of results or conclusions.

TABLE OF CONTENTS

DISCLAIMER	2
TABLE OF CONTENTS	3
Table of Figures	5
1 BACKGROUND	1
1.1 Introduction	1
1.2 Project Description	1
1.3 Original System	1
1.3.1 Original System Structure	2
1.3.2 Original System Operation	3
1.3.3 Original System Performance	3
1.3.4 Original System Deficiencies	4
2 REQUIREMENTS	4
2.1 Customer Requirements (CRs)	4
2.2 Engineering Requirements (ERs)	5
2.3 House of Quality (HoQ)	6
3 EXISTING DESIGNS	6
3.1 Design Research	6
3.2 System Level	7
3.2.1 Existing Design #1: Bioness Vector Support	7
3.2.2 Existing Design #2: SafeGait 360	8
3.2.3 Existing Design #3: Aretech Zero-G Gait & Balance Training System	9
3.2.4 Existing Design #4: Biodex NxStep Unweighing System	10
3.3 Subsystem Level	11
3.3.1 Functional Model	11
3.3.2 Subsystem #1: Stopping Mechanism	12
3.3.2.1 Existing Design #1: Centrifugal Clutch Seat Belt System	12
3.3.2.2 Existing Design #2: Shock Absorber	13
3.3.2.3 Existing Design #3: Spring Shock Absorber	13
3.3.3 Subsystem #2: Trolley	14
3.3.3.1 Existing Design #1: Gear Trolley	14
3.3.3.2 Existing Design #2: Motorized Trolley	15
3.3.3.3 Existing Design #3: Push Trolley	15
3.3.4 Subsystem #3: Track Configuration	16
3.3.4.1 Existing Design #1: Rollon Linear Rail Systems	16
3.3.4.2 Existing Design #2: I – Beam	17
3.3.4.3 Existing Design #3: Box Sliding Rail	17
3.3.5 Subsystem #4: Tether Material	18
3.3.5.1 Existing Design #1: Double Braided Nylon Rope	18
3.3.5.2 Existing Design #2: 7x19 Grade 304 Vinyl Coated Stainless Steel Cable	18
3.3.5.3 Existing Design #2: Antenna Support Rope	19
4 Designs Considered	19
4.1 Design #1: Ground Supported Vehicle Suspension	19
4.2 Design #2: Ground Support Hanging Fruit	20
4.3 Design #3: Overhead Aluminum Truss	21
4.4 Design #4: Mobile Overhead Arches	21
4.5 Design #5: Triangle Beam	22
4.6 Design #6: Semicircle Base Support	22
4.7 Design #7: Ground Supported Mobile Frame Type 1	23

4.8	Design #8: Column Supported Overhead Track System.....	23
4.9	Design #9: Ground Supported Mobile Frame Type 2.....	24
4.10	Design #10: Frame Ground Support.....	25
4.11	Design #11: Adjustable Ground Support.....	25
5	Design Selected.....	25
5.1	Rationale for Design Selection	25
5.2	Pugh Matrices	26
5.2.1	Ground Supported Systems.....	26
5.2.2	Overhead Systems	27
5.3	Decision Matrices	27
	REFERENCES	29
	APPENDIX A: House of Quality	31
	APPENDIX B: Designs Considered.....	32

Table of Figures

Figure 1: Biodex NxStep [1]	2
Figure 2: Arettech[3]	2
Figure 3: Bioness Vector Support [4].....	3
Figure 4: Bioness Vector Support [4].....	8
Figure 5: Safe Gait Support System [5].....	9
Figure 6: Zero-G V.2 [3]	10
Figure 7: Zero-G V.2 [3]	10
Figure 8: Functional Model.....	12
Figure 9: Centrifugal Clutch [6].....	13
Figure 10: Shock Absorber [7].....	13
Figure 11: Spring Shock Absorber [8].....	14
Figure 12: Geared Trolley [9].....	15
Figure 13: Motorized Trolley [10].....	15
Figure 14: Push Trolley [11].....	16
Figure 15: Rollon Track [12]	17
Figure 16: Rollon Slider [12]	17
Figure 17: I - Beam [13]	17
Figure 18: Box Rail [15].....	18
Figure 19: Vinyl Coated Stainless Steel Cable [16]	19
Figure 20: Antenna Rope [17]	19
Figure 21: Ground Support Pugh Matrix.....	26
Figure 22: Overhead Support Pugh Matrix	27
Figure 23: Ground Supported Decision Matrix	28
Figure 24: Overhead System Decision Matrix	28
Figure 25: House of Quality.....	31
Figure 26: Ground Supported Mobile Frame	32
Figure 27: Ground Supported Mobile Frame Type 2.....	32
Figure 28: Column Supported Overhead Track System	32
Figure 29: Hanging Fruit	32
Figure 30: Vehicle Suspension	33
Figure 31: Stage Truss Track System	33
Figure 32: Frame Ground Support	33
Figure 33: Adjustable Ground Support	33
Figure 34: Semicircle Base Support	34
Figure 35: Mobile Arches	34
Figure 36: Triangle Beam.....	34

1 BACKGROUND

1.1 Introduction

In the world of gait study research for patients with neuromuscular deficits such as cerebral palsy or spinal cord injuries, there are cases that state these people endure the fear of falling while undergoing therapy where studies of their gait are performed. Assistive devices to help participants walk have already been commercialized. However, the cost is a large factor for many facilities that study these cases due to the devices being intricate and expensive. The overall goal of this project is to design and engineer a mechanism capable of preventing a patient from falling at a fraction of the cost of the devices already available. It is imperative that this device still meets the same needs and requirements of the researchers and patients themselves. Our team's sponsor, Dr. Zach Lerner, works within NAU's Human Performance Lab where he researches and studies how people with neuromuscular disorders walk. He is in need of a device to help him practice his studies of their gait within his lab. Our team has been contracted to produce a system that can attach to a patient while they undergo Dr. Lerner's studies without having a fear of falling with their disorder. The system must allow the patients to walk under their power. However, it must also protect them from falling if they happen to do so. Issues with current systems are that they are expensive, interfere with motion tracking cameras, take up too much space, and can be uncomfortable to the patient. Our objective is to create a system that is user-friendly, conscientious of space, and affordable.

1.2 Project Description

Following is the original project description provided by the sponsor.

“The Biomechanics Lab uses robotic exoskeletons to improve walking biomechanics in individuals with neuromuscular disorders. Study participants practice walking with the assistive devices in NAU's Human Performance Lab. Because many of the participants have neuromuscular deficits due to stroke, spinal cord injury, or cerebral palsy, they are predisposed to falling. The goal of this project is to design a fall protection system to use during overground and treadmill gait studies. Commercial systems may be difficult to integrate into the existing lab space and are expensive.”

1.3 Original System

This project consists of redesigning existing commercial designs to make them more cost effective and accommodating. In the present market, there are a variety of systems that can complete the task of holding a patient up if they were to fall during a gait study. These systems can either be ground supported or use a track system attached to the ceiling. For a ground support system, the system may be able to be dismantled, allowing it to be transferred from location to location. The disadvantage of this type of device is it may not be able to withstand the amount of force a falling patient may emit. Another type of ground-supported system is one that is small enough to move around a room but not easily disassembled. An example of this sort of device is the Biodex NxStep Unweighing System. The NxStep allows for movement around a room, variety of patient heights, fitment around a treadmill, and collapses to 32" wide [1]. This is not easily disassembled to move to a different location but can be moved from room to room within the same building.

If the falling protection device is not ground supported, it is frequently mounted to the ceiling with a track system. The systems mounted to the ceiling usually have a higher weight rating

allowing them to care for a wider range of patients. Also, as demonstrated by products from SoloStep, they can come in a variety of shapes such as a straight line, j-shaped, u-shaped, and an oval [2]. Each different shape has their advantages and disadvantages based on their application. For example, a physical therapy room may be small in size but the therapist's need to have their patients walk for a longer period. In this case, the best ceiling mounted track shape would be the oval, which allows for the patient to continuously walk without stopping.

These systems mentioned above have been commercialized and are too expensive to be used in smaller gait study or therapy locations. These locations are in need of a system to keep their patients from falling while they are moving around the room as well as walking on a treadmill at a lower price.

1.3.1 Original System Structure

Typical gait study devices come in the form of two styles. The first style localizes itself around a track-mounted system, which is attached to a load-bearing beam above the area where a participant will walk and have their gait tracked. Aretech is a company who produces a device called the Zero G, which is centralized around the track system. The Zero-G incorporates a robotic trolley that automatically tracks patient's movements up to 6 mph [3]. Parts of the original system include a metal track, trolley, and suspension tether. Additional parts include the patient's harness, interactive technologies which track gait, and user-interfaces. The second type of system is a mobile frame, which moves along with the patient as they walk. These types of systems are bulky and are formed with metals capable of supporting the patient's weight. The frames are mounted to a set of wheels that allow the system to move with the patient. An overhead beam built into the frame is usually the place where the patient can be attached via a harness to ensure that they are protected if they happen to fall. Most of the materials of the original system include lightweight metals and durable plastics. These devices are usually housed within therapeutic facilities and research laboratories.



Figure 1: Biodesix NxStep [1]



Figure 2: Aretech[3]

1.3.2 Original System Operation

Another existing fall prevention support system is the Bioness Vector Support in Figure 3. This design has the capability to support up to 500 lbs. of dead weight and can be customized to support a specified amount of weight to relieve from the patient during therapy. The design of the automated motor on the overhead track is unique from others because of the exposed coiled support line on a wheel drum. The onboard-integrated computer system coupled with a hydraulic pump offer precise outputs (such as weight relief) and data collection. The support system also tracks the distance, weight, and number of falls for each therapy session. From the tracking that occurs 1000 times per second, the computer analyzes the data trends and adjusts the cord length and the support of the weight to accustom to the walking patterns of the patient. The Bioness Vector support also has wireless remote to send commands to the support unit [4].



Figure 3: Bioness Vector Support [4]

1.3.3 Original System Performance

Currently, the overhead supported and ground supported support system performances are functional, safe, and interactive. For these original system variations, catching people before they fall to the ground is the main concern considering performance. To accomplish this first major performance concern, static and dynamic force calculations at the tether connected to the track connected to the user must occur. Data collection and customer requirements help compute these calculations for weight, volume, speed, accuracy, power, and efficiency of the system. The original system can hold a maximum of between 400-500 pounds of static body weight and 10-200 pounds of dynamic body weight [4]. Also, the system can perform at various speeds of user locomotion, typically near a maximum speed of 6 mph. In addition to speed performance, the system is also capable of braking when it exceeds the maximum speed, which contributes to a high safety performance for intensive rehabilitation.

The original overhead supported and ground supported systems also include interactive components to track the movements of the user rapidly (at 2500 times per second) and transfer this data to different software that drives the actuator positioned on a track and displays images of highlighted movement [5]. Phones or tablets may be linked to the patient management

software to track patient growth and create/manage care plans. Another interface can link with a mobile device as a remote control for adjusting the system to meet the user needs. The actuator follows the movement of the user while maintaining enough slack in the tether for more comfortable mobility. The actuator simulates freedom of the device for mental awareness strengthening. The slack allows the user to feel free of the device, challenging them, and building their confidence at the same time. Tracking the data and displaying a computer image of movement highlights the areas for the user's mobility improvement and allows for more immediate adjustments that the therapist may direct to the user. Though this interface is not completely relevant to our design problem, it is still relevant to the amount interaction the user has currently with the system and trainer. Our design should strive for a comfortable interaction between the device and users. Overall, the performance of the support system is functional, safe, and interactive.

1.3.4 Original System Deficiencies

The main concern with gait support systems currently available is their cost and interference with data logging motion detection cameras. With commercialized systems costing upwards of \$100,000, they are not feasible for our client's financial situation. Due to this need, our team is focused on designing a system that functions at the same level as one of the expensive devices however at a much lower overall sum. Along with cost, another need for our client that is not met by the original system is interference with motion detection cameras. Some designs utilize a frame, which can obstruct the area the cameras need to be focused on to gather accurate data. Due to this problem, our team has decided that the best option for our client is a ceiling mounted track system, which only has a tether exposed at the level of the cameras. By only having a tether that suspends the patients to prevent falls, the cameras will have better angles to track the patient's gait and overall provide our client with better data for his research.

2 REQUIREMENTS

The following sections will outline the customer requirements our team has set, the rankings are given to us by our client, and the House of Quality used to determine which customer and engineering requirements to focus on.

2.1 Customer Requirements (CRs)

The customer requirements listed below in Table 1 is the requirements expectations of our team by our client and users from the re-design of a support system for gait studies.

Table 1: Customer Requirements

Customer Requirement #	Customer Requirements
1	Safety
2	Treadmill Compatible
3	Must Move 16.5 Feet
4	Easy to Operate
5	Cost to Build
6	Non-Obstructive/Low Profile
7	Un-weighted System (Zero Tensions)
8	Comfortability
9	Minimal Maintenance
10	Reliability
11	Adjustability
12	Non-Reflective
13	Durability

The total cost of the project must abide by the \$2,500 budget set by the client. The design needs to incorporate materials that will economically suit the budget. The overall system must safely support a patient's body weight and movements while being used by the client. The line of sight of the Vicon infrared motion detected cameras must not be restricted. The color/texture of the system cannot interfere with the cameras. The support system allows the patient to use the system when walking on a treadmill. The system must allow the patient to move 16.5 feet in either forward or rearward direction. The tether must not be under tension with the patient attached. The patient must not feel discomfort while operating system to avoid interfering with the gait analysis. The system must be easily operable by both the patient and the therapist. The design needs to have minimal maintenance required over long durations of operation. The system must be able to be operated for long periods. The system must not fail when being used and must catch the patient from falling. The system must be able to be used for small children to elderly adults ranging in heights and weights.

2.2 Engineering Requirements (ERs)

The top section of the House of Quality is the engineering requirements section, which outlines what our team needs to focus on in the design process. The engineering requirements are correlated to themselves as well as the customer requirements to determine which ones should be focused more on. The cost of materials is the engineering requirement that weighs highest as found by the house of quality being the top by over one hundred points. The target for the cost of materials is \$2000 because we need to have budget left over for the installation and maintenance costs. Almost every engineering requirement listed in Table 2 below can link back as an effect to the cost of the materials used. The next important engineering requirement is having the force of the fall protection tether not exceed its breaking limit. This engineering requirement is still in the analysis process for calculating but is so critical to providing the safety that it scored second highest in the house of quality point summation. The third place of focus importance is the frame breaking force that ensures the entire system will have enough strength to support consecutive user falls. This focus on the frame breaking force is still under analysis as well because there is not a definite frame design set yet. Once we choose our frame design, we will be able to relate better force equations to return a more accurate target for this requirement.

Table 2: Engineering Requirements

Engineering Requirements	Measurement Unit
Cost of Materials	\$
Installation Cost	\$
Maintenance Cost	\$/yr
Moment of Support Arm Must Not Exceed	Ft lbs
Force On Tether Must Not Exceed	lbf
Patient Weight Rating	lbs
Tether Breaking Strength	lbs
Weight of Unit <150 lbs	lbs
Emisivity >= 0.90 (Non Shiny)	-
Minimal Frame Members	-
Max Collapsed Width of 35 Inches	Inch
Max Collapsed Height of 80 Inches	Inch
Max Assembled Height of	Inch
Minimum Assembled Width of	Inch
Minimum Assembled Length of	Inch
Ability to Travel 16.5 Feet	Feet
Minimum Travel Speed of 6.7 Ft/sec.	Ft/sec.
Time to Assemble / Disassemble	Mins.
Force to move System Less than	lbf
Force From Tether On Patient Less Than	lbf
Lifespan of Unit Minimum 5 Years	Years
Adjustable Height of 2' to 7'	Feet
Catching Time =< 1 sec.	Sec.
Motor Actuation Force	lbf
Tether Elasticity	psi
Frame Breaking Force	lbf

2.3 House of Quality (HoQ)

The House of Quality in Appendix A: Figure 25 is an engineering tool used to define the relationship between customer requirements and the engineering requirements as well as other products on the market. Currently, our HoQ has the customer requirements with the client rated weight in a number of 1-5, the engineering requirements, and the strength of the relationship between engineering requirement and customer requirement. The compilation of the rankings and relationships yields a product of the absolute technical importance and relative importance.

3 EXISTING DESIGNS

Our team has conducted a variety of research to successfully re-engineer a support system for fall protection during gait studies. This type of system already exists in the marketplace, however, are very expensive and not practical for personal uses.

3.1 Design Research

Our team conducted research on several overall systems and subsystems found in a fall prevention support system. The four overall systems include Bioness Vector Support, SafeGait 360, Aretech Zero-G Gait and Balance Training System, and BioDex NxStep Unweighing System. These four devices range in how they operate, prevent a fall, and study gait. Our team focused mainly on ceiling track-mounted systems for our subsystems. The four subsystems include a stopping mechanism, track system, trolley, and a tether to connect to the patient. The user interface allows for easy operation and collection of gait analysis by the trainer. The trolley is used to catch the patient from falling but move with the patient when they are walking. The trolley will be mounted to the track system, which is then mounted to the ceiling to ensure a sturdy and reliable device. The tether is used to connect the patient to the trolley to prevent a fall. However, after further contact with our client, we were informed to switch from focusing on an overhead mounted system to a ground supported system. This is due to our client relocating to a different laboratory.

Our team did all of our research by utilizing the search engines such as Google. This allowed us to view a number of devices already in the market in a quick amount of time. The manufacturer's websites do not discuss the design portion of the device but rather the applications of their systems. The application details found on their websites helped us develop an idea of how we may want to alter their designs to suit our project needs better. For example, a portable system with many different members may block the view of the infrared motion detected cameras. To solve this, we may re-design it only to have one member connecting to the patient where the cameras are not located to not interfere with the gait studies. The following sections will discuss the four overall systems and four subsystems.

3.2 System Level

3.2.1 Existing Design #1: Bioness Vector Support

The Bioness Vector Support (BVS) system is one of the supports that a physical therapy office might purchase. The BVS meets several of the Customer Requirements (CR) of ease to operate, un-weighted system, adjustable, weight support, and treadmill compatible. The BVS also does not meet highly important customer requirements of cost to build, durability, and minimal maintenance. Beginning with the strengths of the BVS system that meet the CR's is the weight capacity to hold up to 500 lbs. [4]. This model specification supersedes the maximum amount of weight required and could yield information on how our design can incorporate the same engineering designs to hold up to 300 lbs. Another detail of the BVS is the capability that it can be erected to run on an overhead track of five meters or more including over treadmills. The BVS can also adjust the amount of weight to withhold from the patient all with a touch of a button from a smartphone, tablet, and or computer [4]. This specification is useful to our project because of the CR to have zero tension in the tether attached to the harness. The tension in the line would interfere with the patient's ability to perform the therapy exercise correctly. Indirect link to tension is the comfortability of the design on the patient. The BVS system uses the adjustability of the chord length to accommodate the patient's unique body by allowing enough slack in the tether, not to be pulling on the harness, while also maintaining a slight tension to prevent minimal free fall and agile response to a falling patient.

While the Bioness Vector Support has many attributes that meet several of the customer requirements, there is also some design of the BSV that don't meet some of the CR's. The system cost of the BVS is ten times or more than the \$2,500 project budget. While the BVS system is of high quality and has minimal maintenance, the support would require maintenance a special technician will be sent to perform the work necessary to repair or maintain the device. The repair could add additional cost to the overall ownership cost for the client. In our design, it will be important to ensure the support system will have less than minimal maintenance, if none at all, and could be maintained by any mechanically experienced personnel rather than a special technician.



Figure 4: Bioness Vector Support [4]

3.2.2 Existing Design #2: SafeGait 360

The SafeGait 360 is an interactive support system currently on the market that specializes in balance and mobility training. This system is composed of six major components- rail, actuator, harness, closed wireless system, patient management software, and hardware. The rail may be fixed from the ceiling and customized as a straight or full loop configuration, “U” or “J” shaped. This rail design accommodates for the facility space and requirements - such as treadmill accessibility. An actuator attached to the railing is “a stealth, state of the art support and tracking device that moves with the patient” [5]. Though an actuated patient tracking system is not necessary for our design, utilizing this type of technology will reduce the frictional resistance caused by the patient's connected movement, which is a customer requirement. Acceleration of the user matches the motion of the actuator, which helps the user keep balance and have the illusion of walking freely with confidence. The harness design was generated from therapists to maximize the patient's comfort by introducing counter-uplifting forces with leg cuffs and straps around the torso. Next, the support system interacts within a closed wireless system that provides security, privacy, and connectivity. The closed wireless system ensures no other wireless signals will interfere with the rehabilitation device, minimizing the source of error. Another system component is the patient management software that uses a smart and user-friendly interface to manage patient statistical data and customize a care plan. Data gathered from the therapy sessions can detail summary of progress and export this progress in a chart format into the patient health records. Lastly, the hardware connects with this software with a mobile device, such as a phone or tablet for flexible control options.

Since safety is the ultimate goal for this system, four major device components are implemented - dynamic fall prevention (DFP), falling length limits, body weight support, and a horizontal lock. Two of these functions are requirements for our design: falling length limits, body weight support. The dynamic fall prevention is software that can distinguish between a user's intentional movement downwards and when they are experiencing a fall. This software can adjust sensitivity levels of the patient at varying independence stages - low, medium, and high. The backup fall protection feature is a decent limiter that sets a maximum downward travel distance based on the patient's position and height. Having a backup fall preventing device is something to consider for the design of our support system to ensure safety. Another safety feature is the body weight support, which can adjust to unload the patient up to 50% of their

weight at a 175-pound maximum. The final major safety feature is the horizontal lock that allows for vertical travel as desired for a steady place to anchor onto a treadmill or for push/pull training. In all, this system is an exemplary device that facilitates valuable patient/ therapist interaction in a modern, safe, and efficient environment.



Figure 5: Safe Gait Support System [5]

3.2.3 Existing Design #3: Aretech Zero-G Gait & Balance Training System

There are a handful of current commercial gait training systems on the market today. One of these systems is Aretech's Zero-G (Figure 6,7), which is a ceiling mounted track system that suspends the patient from an overhead robotic trolley. The technology integrated into this design is advanced in that it has an interactive data analysis system, which tracks a patient's gait and is displayed on an interface that both the patient and therapist can view. The Zero-G offers a wide range of patient diagnosis from spinal cord injury to cerebral palsy and has a weight range of 20-400lbs [3]. The Zero-G allows a variety of functionality allowing a patient to practice walking, balance-activities, postural tasks, sit-to-stand exercises, stair walking, and getting up off of the floor. The robotic trolley allows tracking of a patient at up to 6 mph and is offered in track sizes of up to 85 feet [3]. Tracks can be configured in straight, J-curved, U-curved, or customized options to permit installation in most facilities [3].



Figure 6: Zero-G V.2 [3]



Figure 7: Zero-G V.2 [3]

The Zero-G is a well-renowned system that incorporates requirements important to implement into our design. The overhead track system is of particular interest to our team, as our client wants to conserve as much space as possible within his research laboratory. A track configuration allows the system to keep up and out of the way of the floor space when not in use. Another component that the Zero-G includes which we are also considering incorporating in our design is a frictionless trolley, which lets the patient move freely wherever the track allows them too. Wide range patient compatibility is another important need of our client that the Zero-G utilizes in its design. The ability to offer a size range from child to adult is essential as research can be conducted on virtually any patient. Our client also requires that our design will have the ability to be used on a treadmill. Having an overhead suspension system like the Zero-G is vital because the tether in which the patient is strapped to can be retracted to allow for obstacles like stairs or a treadmill to be inserted under them. After conducting a thorough investigation into Aretech's Zero-G, there are multitudes of ideas our team may utilize in our design.

3.2.4 Existing Design #4: BioDex NxStep Unweighing System

Another design our team is interested in is the BioDex NxStep Unweighing System, which utilizes a mobile system to prevent patients from falling. This device can be used for patients who have had a spinal cord injury, stroke or traumatic brain injury, Parkinson's disease, older adults, amputation of a lower extremity, orthopedic patients, and much more [1]. This system allows for the user or therapist to select the amount of weight to take away from the patient and to raise or lower the height bar depending and the height of the patient. The weight load variation can be very useful because if someone has a very hard time holding their weight, this system can take up to 400 pounds to help the person start to walk with less weight on their legs [1]. The overhead bar is connected to the harness to allow for distribution of forces the patient may feel if they were to fall. The overhead bar is then connected to a tether at a single point. This system can be used with a treadmill to allow gait studies to occur without having the patient be constantly moving around the room. In this case, the patient can be in one place but still have movement. As a bonus, the system does come with two different therapist seats; one on either side of the system to allow for a comfortable working environment for the therapist while the patient is on the treadmill [1].

This system is a very important system to us for several reasons. First, the system can fit around a treadmill which is one constraint given to us by our client. Secondly, the system does not fill a lot of space within the room to hold the patient up in the event of a fall. A concern from our client was that if we were to build a mobile system, then it would interfere with the motion tracking cameras that are set up. The NxStep has very low interference with the motion-detected cameras due to the minimal number of members that make up the frame. Lastly, the system can hold a patient weighs up to 400 pounds. The weight limit we have been given is around 250-300 pounds to withstand. It would be in our best interests to break down this system and see exactly how it can withstand 400 pounds safely and how we can utilize that within our designs to hold 250-300 pounds.

3.3 Subsystem Level

At a subsystem level, the general, existing designs can be decomposed into User Interface, Brake and Motor, Track, and Tether. Each of the subsystems is critical components that existing designs on the market apply different engineering designs. In this section is the result of research from the existing subsystems that could influence the future concept generation process. Along with the research is an analysis of the existing subsystems fulfillment of the customer requirements.

3.3.1 Functional Model

The functional model below in Figure 8 is a decomposition of the important functions our design must meet. The purpose of the model is to help the design team to understand as well as clearly display the complexity within the system that will be designed. The first function of the system is to bring in some source of electricity to supply to a motor. Our team decided that it would be important to include a motor to move the weight of the support system rather than the patient moving the support system. The benefit of having a motor would be that the comfort of the patient would increase as well as the compatibility to move 16.5 feet. The next function is the "Actuate Elect." function. This function drives the system forward without requiring effort from the patient. It also sends a signal to the mechanism used to stop the patient from falling. The final important function is when the input of the human is when the patient is falling. In the event the patient falls, there are a function input and output to prevent this motion from continuing. This function is a motor or servo used to stop the patient from falling. The entire functional model is critical to the success of our team's design as it helps to direct integral functions of the design that need to meet the customer requirements.

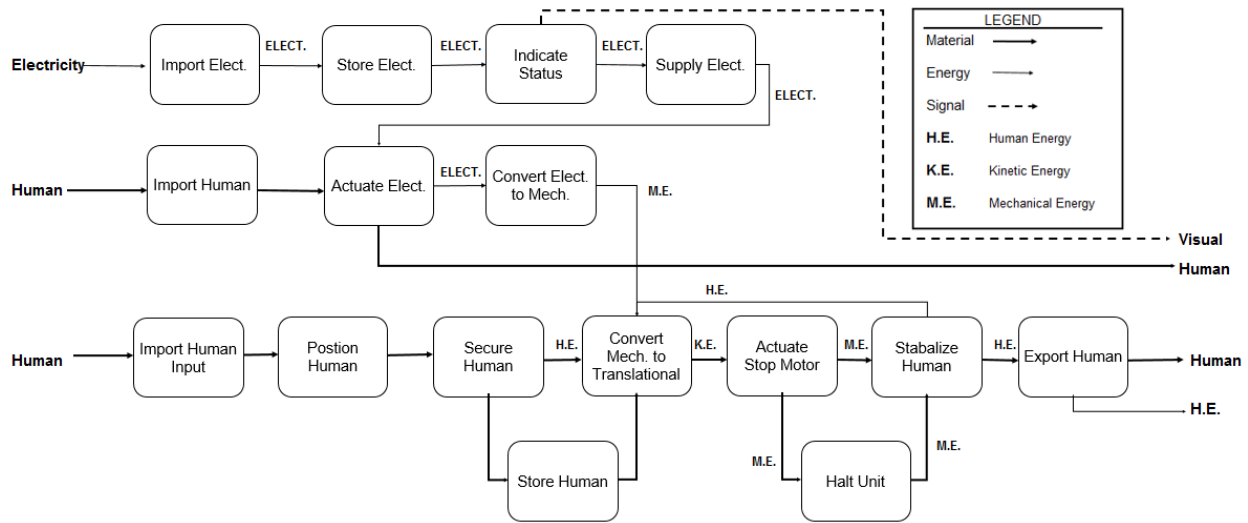

Figure 8: Functional Model

3.3.2 Subsystem #1: Stopping Mechanism

One of the most critical components of the system is the ability to stop a patient from falling. The stopping mechanism needs to satisfy the safety, reliability, durability, and cost customer requirements. Each of these requirements will help to ensure that the research of the human interfaces will contribute to future engineering concepts and design.

3.3.2.1 Existing Design #1: Centrifugal Clutch Seat Belt System

A common method used to bring a human body to a halt is the seat belt mechanism found in automobiles. This system is seen in Figure 9, works by a rotating ratchet gear with a clutch lever fastened to the outer edge that when a specific rotational velocity is achieved the clutch extends outward past the edge of the ratchet. When the clutch is extended this far, it catches a cam which actuates the pawl. The pawl is forced into the rotating ratchet, which then stops the rotation of the ratchet. The ratchet is attached to the spool from which the tether is unwound [6]. The strength of this system is in the reliability to stop a body in motion. The seat belt mechanism is also cost in a range from \$100 - \$200 range. The weakness of the system is that it will require some changes to use with children. Though the patients using the device will not be traveling as fast as those in vehicles, the centrifugal clutch system will still be a design from which our team can stem future ideas.

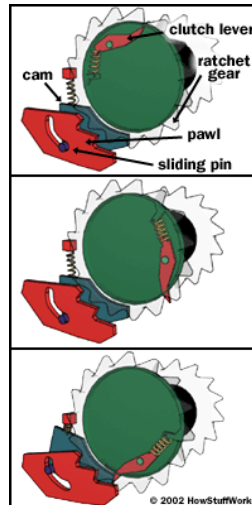

Figure 9: Centrifugal Clutch [6]

3.3.2.2 Existing Design #2: Shock Absorber

An unconventional subsystem that can be used is a shock absorber. The shock absorber system seen in Figure 10 is a design used to reduced vibrations in vehicles or any mechanical system. How our team could use this system is by utilizing the shock absorbers ability to take kinetic energy and convert it into heat energy through compression of the hydraulic fluid in an extension cycle (system in tension) [7]. Rather than stopping the patient abruptly in a fall like in the previous centrifugal clutch subsystem, the shock absorber would slow the patients falling speed to a gradual velocity of around a few inches per second. The passive falling speed would allow the patient and or the accompanying therapist to catch or help the patient to avoid the high risk of falling injury. Hydraulic shocks can cost around \$50 – \$150 each, which would not be a burden on the project budget.

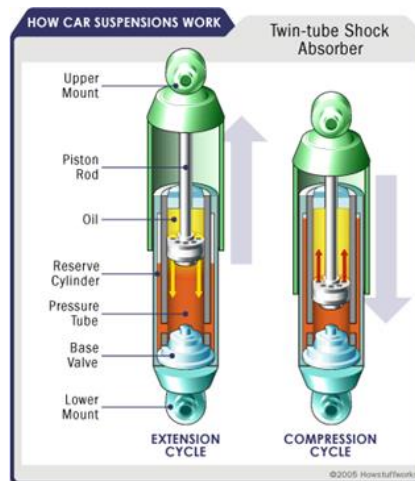

Figure 10: Shock Absorber [7]

3.3.2.3 Existing Design #3: Spring Shock Absorber

A similar subsystem to the hydraulic shock absorber is the spring shock absorber. The spring shock works by the tension of each end of the shock, which then causes a compressive force on the spring. This system would slow a patient fall and bring them to a stopped position completely. The spring in the shock would also provide some relief to the patient bearing their weight after they have fallen, making it easier for the patient to regain their balance. Because of

the simplicity of the shock absorber design, minimal maintenance would be required. Additionally, the shock absorber would be durable enough to handle the cycling of the patient weight. While the spring shock would not be adjustable, the project design would have to ensure that the shock could be interchangeable to work with varying weights. The reason it must be interchangeable is due to the spring being too stiff for lighter weights and would make it very uncomfortable for the patient when they fall.



Figure 11: Spring Shock Absorber [8]

3.3.3 Subsystem #2: Trolley

Using a track system requires a trolley to attach on the track, move smoothly along with a user's motion, and hold the weight of a person up to 500 pounds. There are three different trolley options to meet the needs of our system - geared, motorized, and push trolleys.

3.3.3.1 Existing Design #1: Gear Trolley

This type of trolley helps provide positive load positioning along the total beam that will fit most I-, S-, and W-beams. The geared trolley is designed with baked enamel paint for protection and precision ball bearing wheels. A benefit to this all-steel construction with hardened axles and lubricated wheel design is its durability and wear resistance. The extra durability will help keep the system safe. Additionally, the geared trolley has an easy installation to hoists. Another benefit of this design is the precision provided by the hand chain gear system. This precision would help guide the user with confidence for the purpose of our system by manual adjustments made by the professional physical therapist. The hand gear system is also good because it does not require power equipment to do the work over straight or curved tracks. In all this is a reliable and efficient device to use for the trolley component [9].



Figure 12: Geared Trolley [9]

3.3.3.2 Existing Design #2: Motorized Trolley

The motorized trolley is described as durable, reliable, and powerful. This design has larger wheels than similar models, to maintain and withstand severe use at or near rated capacities. Additionally, this trolley is easily adjustable for a range of different beam widths big or small. The trolley is powered by TENV (Totally Enclosed, Not Ventilated) motor that is designed to ventilate but also prevents liquids and solids from entering the machine. This type of motor is also compatible with a remote control to hoist and move loads with a push of a button. Lastly, the motorized trolley can have added on features that will increase brake and gearbox life as well as reduce power consumption. This will be a good option for our design because of the adjustability and durability factors [10].



Figure 13: Motorized Trolley [10]

3.3.3.3 Existing Design #3: Push Trolley

The push trolley is the last option for the system, capable of 1/4 to 3-ton capacities. Included with the device are lifetime lubricated precision ball bearings that ensure minimal manual effort and limited maintenance. A specific push trolley from the company Chester Hoist is equipped with “eight duo-sealed Timken tapered roller bearings that absorb the radial and thrust loads exerted in [the] heavier sizes” [11]. This means a greater surface area of contact for the bearings and track that helps create a fluid motion with minimal friction. The stability and rigidity

for the trolley come from the shaped heavy rolled steel side plates that extend beyond the wheels to behave as bumpers. Steel equalizing pins that provide smooth operation and load equalization connect the two halves of the trolley. The wheels of the trolley are long, made of cast iron, and have machined threads for extra smoothness for rolling motion. The axles in the side frame are made of steel for rigid support; also steel trolley blocks reinforce the side plates as well as equalize the pin. A push trolley design is beneficial to our system because it is free from a power source, has low friction, and a high weight capacity.



Figure 14: Push Trolley [11]

3.3.4 Subsystem #3: Track Configuration

In this subsystem, the track is one of the parts that has infinite designs and options. From rails to beams, the selection of the right track is critical to meeting requirements of cost, durability, safety, reliability, and minimal maintenance. The research of existing designs shows tracks that are found in industrial applications to support systems.

3.3.4.1 Existing Design #1: Rollon Linear Rail Systems

Rollon Linear Evolution's compact rail systems are track configurations available in T, K, and U profiles made from 100Cr6-hardened steel [12]. These tracks, seen in Figures 15-16, are designed for applications in aerospace, medical, railways, automation, industrial machinery, and logistics. The tracks consist of induction hardened raceways and high precision radial ball bearing sliders that are affordable and easy to install on all types of surfaces including non-machined surfaces. They have two slider types: N-series aluminum die-cast bodies and C-series with steel bodies. The sliders are resistant to dirt and other forms of debris and include lubricated-for-life bearings. Technical features include max operating speed of 9 m/s, max acceleration of 20 m/s², and a max radial load capacity of 15,000 N (337 lbs.) [12]. These track systems also allow for adjustable preload.



Figure 15: Rollon Track [12]



Figure 16: Rollon Slider [12]

3.3.4.2 Existing Design #2: I – Beam

Another form of track structure that may be suitable for our design is an I-beam. I-beams are available in a wide range of sizes and materials such as aluminum and steel. An I-beam can be a simple solution for a track to mount a trolley on as they are capable of supporting heavy loads and can be machined for a close to the frictionless surface for wheels or roller bearings to move along. Although there is a tendency for I-beams to be expensive, they are capable of meeting our client's need of being able to support a max patient weight of 300lbs.

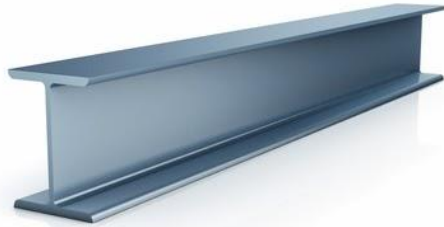

Figure 17: I - Beam [13]

3.3.4.3 Existing Design #3: Box Sliding Rail

Real Sliding Hardware is a company that produces industrial grade sliding hardware. Their typical system consists of a rail trolley that moves inside of a box rail track. Real Sliding Hardware, found in Figure 18, has designed their box rails to be used in exterior or interior applications and are formed out of galvanized or stainless steel that can be powder-coated to customer specifications. If a personalized order is requested, Real Sliding Hardware can be manufactured to custom track lengths and applications. Kit sizes are available in a range of 6-50 feet with their strongest box rail being capable of supporting 800 lbs. [14].



Figure 18: Box Rail [15]

A box rail track could function as a useful design to base our trolley mechanism off within our system. With steel as a structural base for supporting the patient, the integrity of a box rail track will meet our client's requirements of safe and reliable. The ability for application customization may also be helpful in fulfilling our client's requirement of a low profile and non-reflective track system.

3.3.5 Subsystem #4: Tether Material

Support systems, such as Bioness, or Areteck, use a different material to secure the patient to the support system overhead. The selection of material is important because of the repeated stress that will be put on the tether during normal use. Existing tether uses to support patient's o from synthetic polymers to metallic cables. The tether is also an important part of meeting the safety, reliability, and durability requirements.

3.3.5.1 Existing Design #1: Double Braided Nylon Rope

There are several materials one can use to keep a person from falling. One of these materials is a double braided nylon rope that can come in a variety of sizes to withstand a range of tensile strengths. For example, a size of ¼-inch thick double braided nylon rope has a tensile strength of 2,200 pounds on average [16]. For our project, we will first need to calculate the max amount of force that will be exerted by the patient onto the tether to know what thickness our tether will need to be. The double braided nylon rope distributed by Knot and Rope Supply come in thickness from ¼ inch to 1 inch where the one inch has a tensile strength of 26,000 pounds on average [16].

3.3.5.2 Existing Design #2: 7x19 Grade 304 Vinyl Coated Stainless Steel Cable

Another option for a material being used as a tether would be a stainless-steel cable coated with vinyl. This type of cable will be able to support on average from 350-1800 pounds depending on the thickness of the cable [17]. The vinyl coated stainless steel cable will provide less friction on the trolley making it easier for the patient to walk with the tether attached. If the tether cable were to have a high frictional force going against the patient, the patient will have a harder time walking and will affect the gait analysis. The stainless-steel cable in Figure 19 also has high flexibility, corrosion resistance, and abrasion resistance. The flexibility will become very useful in our design, as we do not want a tether that is extremely tight on the patient because if the patient were to fall, the force from the cable onto the patient would be enormous, possibly causing injury. The image below is an example of 5/16 inch, 7x19 Grade 304 Vinyl Coated Stainless Steel Cable.



Figure 19: Vinyl Coated Stainless Steel Cable [16]

3.3.5.3 Existing Design #2: Antenna Support Rope

Antenna support rope manufactured from Synthetic Textile Industries is a cheaper, yet very strong material a tether. The diameter of the rope is 5/16 inches with a breaking strength of approximately 1,790 pounds [18]. Antenna support rope is made from double braided polyester rope to ensure the reliability and durability of the system. This rope is distributed from DX Engineering and costs about \$25 for 100 feet, which is more than enough for our application [18].



Figure 20: Antenna Rope [17]

4 Designs Considered

This section covers eleven different designs created and considered by the team to best fulfill the customer requirements. Each design also divides to its subsystems for a functional decomposition. These considerations provide assistance in further analysis for deciding advantages and disadvantages of the overall system.

4.1 Design #1: Ground Supported Vehicle Suspension

The vehicle suspension is a collaboration of a vehicle suspension design and a bio frame

design from a tree. From the bio-inspired side, the support frame in Appendix B: Figure 30, which looks like a large “Y,” is mimicking a tree from the base to the main branches. At the ends of the branches is where the vehicular inspired design is introduced by the suspension system. The suspensions system is based on an interchangeable spring shock suspension that is compressed when under tension. This would allow a patient to fall, but at a steadily declining rate until reaching zero velocity. The patient would not be allowed to fall to the ground, but only to free fall a short distance to reduce whiplash. The system also has lasers located near the wheels. These lasers are sensors to detect when the patient's feet have crossed the front of the system (Indicated by the dotted line in Appendix B: Figure 30) which then actuates the motor (powered from the onboard battery) and moves the system forward half a foot. This operation is intended to remove the weight of the system being carried by the patient. The design also includes a remote for the therapist to control the speed of the motor manually so that the design can move around the room with or without the patient.

Table 3: Ground Supported Vehicle Suspension

Advantages	Disadvantages
System moves its weight rather than relying on patient to move	Higher cost of motor, suspension, and sensors
Adjustable motor speeds	Requires charging
Interchangeable shocks	Higher maintenance from motor suspension

4.2 Design #2: Ground Support Hanging Fruit

Another bio-inspired design is the hanging fruit design based on how a tree supports a fruit, such as an apple, orange, and lemons. These kinds of fruits that hang from the branches are hanging from thin stems that lead to the major supporting branches. The design uses this technique of nature by using a single stem or supporting beam seen in Appendix B: Figure 29. The design uses a motor, powered by an onboard battery, to provide the necessary length of the tether. Attached to the motor is a ratchet gear that stops when in contact with a key. A spring sensor at the top of the support frame actuates the key. When the spring is compressed too far, from the weight of the patient falling, it triggers the sensor and then actuates the key to stop the ratchet to prevent the spool from unwinding. When the spool is prevented from rotating the patients fall is stopped in a short distance and time. The design also uses a pulley system with a hydraulic press to adjust the tension in the tether. Lastly, the hanging fruit design uses sensors at the front of the ground portion of the frame to actuate the motors on the wheels to move forward the desired distance according to the patient's speed.

Table 4: Ground Support Hanging Fruit

Advantages	Disadvantages
Cost to build is feasible under the current budget	Maintenance for motor, hydraulic, and sensors
System moves its weight rather than relying on patient to move	Requires charging for battery
Adjustable speed and tether length	
Safety stopping mechanism	

4.3 Design #3: Overhead Aluminum Truss

The aluminum truss design in Appendix B: Figure 31 is based on event staging. This type of overhead track system allows the client to collapse the entire structure to make the unit mobile to another location. The aluminum trusses are similar to building blocks and can be customized to a new room with different dimensions. The center overhead truss also can move on rollers across a track allowing the client to maximize use around the room. Underneath the center truss is the track on which the support system rolls freely (seen in lower half of Appendix B: Figure 31). This setup allows the user the capability to move in an x - y plane. Within the support system is a motor used to retract and loosen the length of the tether. Another motor is used to drive the support system along the track. The buildings AC Voltage supply power each motor. The tether coming off the spool runs over a pressure spring sensor which if compressed too far actuates a disc brake attached to the spool and preventing the patient from falling.

Table 5: Overhead Aluminum Truss

Advantages	Disadvantages
Maximizes use of space in a room	Requires power from local source
Ability to be collapsed and reconstructed	Higher maintenance
System moves its weight rather than relying on patient to move	Higher cost because of extra materials

4.4 Design #4: Mobile Overhead Arches

This design incorporates arches to support a mobile track system. The first considered subsystem is the arch structure attached to the center I-beam that allows for a sturdy system that allows movable clearance to station over a treadmill. The arches are designed in a truss manner and the material considered is some aluminum or steel to ensure stability. The I-beam is a minimum length of five meters, so the user has this amount of length to move at a minimum. A push trolley is attached to the overhead I-beam with frictionless bearings that allow the user to have effortless fluid motion. The trolley is equipped with long cast iron wheels with machined threads as well for extra smooth rolling motion. A harness attaches to the trolley with a tether to the fall protection device that sets a falling length on the size of the user. The tether will have an elastic quality to better brace the fall as well. The last subsystem includes the

rollers that the entire system rests on that allows mobility around the room. The roller tracks are designed to run parallel with the support I-beam, and wide enough to fit over a range of treadmills while retaining mobility. Once the structure is in its desired position, the rollers are lockable to keep the entire structure set in position. Listed below are the advantages and disadvantages of this mobile arch design concept.

Table 6: Mobile Overhead Arches

Advantages	Disadvantages
Easy to operate	Reliability
High safety	Tension on patient
	One direction user mobility

4.5 Design #5: Triangle Beam

The triangle beam is a design concept that contains an overhead support built on wheels for mobility. The system structure incorporates square truss supports in the shape of triangles at each end that connects a triangle truss beam for the overhead support. The overhead cable track is a minimum length of five meters and attaches to the overhead triangle truss beam with tension rods. Having a single cable for the track helps reduce the friction created by the user's movement because of its lightweight. The user will connect to the overhead support simply with a harness connected to a fall protection tether device. This fall protection device is set at a fall height adjustable to the user's size, and the tether is made with an elastic ratio to help brace the fall. The system rests on top of low friction, lockable, low profile wheels tracked to run horizontally with the cable track, and the width of these tracks is large enough to fit over the desired treadmill. The low profile wheels can lock with a flip of a switch that can be kicked or tapped by a foot to activate.

Table 7: Triangle Beam

Advantages	Disadvantages
Low cost to build	Obstructive
Minimal tension	Durability
Mobility	

4.6 Design #6: Semicircle Base Support

This considered design has a semicircle as a base inspired by a boxing bag holder. The first subsystem to consider is the semi circle base that must be wide enough to fit the designated treadmill and sturdy enough to have three bending supports that link the overhead support. Three supports attach to the base; one directly in the middle of the semi circle base and the other two to the left and right. These supports are designed to be flexible enough to bend with a user's fall to help brace the fall impact. All three of these supports rise vertically then curve to meet in one place overhead that creates a junction to attach the hanging fall protection device. The fall protection device is a simple tether system that can adjust to the size of the user, and the tether is chosen to have an elastic value to help brace the fall for comfortability

purposes. The whole structure rests on low profile wheels that allow a wide range of motion as well as capable of locking in place if necessary. Overall, this design has minimal parts, which will help keep the cost low.

Table 8: Semicircle Base Support

Advantages	Disadvantages
Low cost to build	Durability
Mobility	Tension on the user
Safety	

4.7 Design #7: Ground Supported Mobile Frame Type 1

To meet our client’s requirement of a portable system our team came up with several different concepts of ground supported mobile frame. This particular design consists of steel tubing once again to form the frame itself; however, the orientation of this system differs from design seven in that it has more components. The frame will have two base pieces of the same dimensions to create a heavier system. The extra weight will provide better resistance against the force from the patient during a fall. This is a key component, as the system will not tip over during a fall ensuring the safety of the patient. This system will utilize a vertical support column with a horizontal beam to hoist the tether just like design seven. The benefits of this style of the system are that it is on wheels so it can be rolled to wherever it is needed within the lab, it is durable and long lasting, and most of all it’s very safe regarding fall protection. These benefits outweigh the disadvantages and meet nearly all of our client’s requirements.

Table 9: Ground Supported Mobile Frame Type 2

Advantages	Disadvantages
Safe system	Requires force from patient
Mobile/portable	Will exceed allotted budget
Treadmill compatible	Obstructive to motion detection cameras
Vertically adjustable	Bulky

4.8 Design #8: Column Supported Overhead Track System

Another form of design our team will possibly pursue is an overhead track mounted system. Within this design, the goal is to utilize the entire laboratory our client has available to mount an overhead beam to suspend the patient. Having a beam mounted overhead allows the system to be out of the way of the motion detection cameras our client needs to track the gait of his participants. The track will be the main component of the system as it allows for the use of a trolley in which the patient can be hoisted. This system will have four vertical columns located in each corner of the laboratory. Fastened to the vertical columns will be two beams that span the length of the facility. These beams will support the cross member that houses the track component of the system. Attached to the track will be a trolley that will control how much tether

needs be extended to allow for a multitude of patient sizes and will be designed to halt if a patient happens to fall. The trolley is a mobile component that will move along with the patient as they practice their gait within the lab. Having an overhead track makes it easy for the system to be compatible with a treadmill. Our client requires that our fall protection system is capable of being mobile, can allow varying patient sizes, and most importantly protects the patients from injuring themselves when practicing their gait. The column supported overhead track system meets all of these requirements.

Table 10: Column Supported Overhead Track System

Advantages	Disadvantages
Non-obstructive to motion detection cameras	Will exceed the allotted budget
Treadmill compatible	Requires long assembly time
Allows for varying patient sizes	Centered in middle of laboratory
Ability to traverse over 5m	Not very portable

4.9 Design #9: Ground Supported Mobile Frame Type 2

To meet as many of our client’s requirements, our team developed multiple ground-supported systems. One of these is a ground supported mobile frame, which utilizes steel tubing formed into a U-shaped base with a vertical column that supports a beam at the top end to hoist the patient. The base incorporates wheels designed to be as frictionless as possible to provide the least amount of resistance from the patient to initiate its movement. Having a beam that expands horizontally from the top of a vertical column allows the patient to be suspended from a tether attached to it. In the case of a fall, the force the patient exerts on the tether will be driven through the horizontal beam into the rest of the frame. The frame will be designed to counteract the force from a fall and keep the patient safe from injury. The ground supported mobile frame will have adjustable legs horizontally and vertically to allow varying patient sizes as well as the ability to fit through a doorway while still being compatible with a variety of treadmill sizes. This adjustability, as well as the ability to be portable and mobile, are all requirements of our client.

Table 11: Ground Supported Mobile Frame

Advantages	Disadvantages
Treadmill compatible	Force required from patient to move
Ability to travel at least 5m	May exceed budget allotted
Vertically/Horizontally adjustable	Will take up space within facility
Portable system	Possibly obstructive to motion detection cameras

4.10 Design #10: Frame Ground Support

The frame ground support design includes a frame around the patient. The system will include a set of locking wheels, sturdy frame construction, and a tether mechanism above the patient. The locking wheels allow for movement of the system around the room as the patient is walking but will lock up when the patient exerts a certain force on the system if they were to fall. If the patient were to fall, the system would not continue to roll potentially causing further injury to the patient. The two side members of the frame will extend vertically from the center of the bottom members with four ribs to prevent bending of the vertical members. The top member will then connect to the vertical members and will house the tether mechanism. The tether mechanism will act similar to the locking wheels by locking the tether when the patient exerts a certain force on the system.

Table 12: Frame Ground Support

Advantages	Disadvantages
Portable	No Vertical/Horizontal Adjustments
Treadmill Compatible	Obstructive to side cameras

4.11 Design #11: Adjustable Ground Support

This design is a ground-supported system, which includes a weighted back end to resist the moment on the support arm if the patient falls. It has the same locking wheels mechanism as described in the previous concept, however, due to the weight, there will be more wheels below the horizontal members to distribute the force from the weight better. The legs of the system below the weight and the member above the weight where the support arm connects will be vertically adjustable to make the system fit a variety of heights. The support arm will extend outwards from the vertical members with the tether mechanism attached at the end. The tether will then protract from the mechanism down to the patient and will connect to the patient's harness.

Table 13: Adjustable Ground Support

Advantages	Disadvantages
Portable	Obstructive to rear cameras
Treadmill Compatible	More weight on patient
Vertically Adjustable	Heavy
Resists Moment on Support Arm	

5 Design Selected

5.1 Rationale for Design Selection

Through arduous execution of decision and Pugh matrices of our various concepts, we agreed that we would pursue design seven, the ground supported mobile frame. Our selection of design seven came from our personal likings as well as its high scores within our tests against the

other options. The ground supported mobile frame has appealing attributes such as its adjustability, mobile configuration, as well as high level of safety. This fall protection device meets, and in certain circumstances, exceeds our customer's requirements. This device is capable of moving at least 5 meters, can function with multiple types of treadmills, and is capable of supporting varying patient types. The major disadvantage of this system is that its overall cost will probably exceed our allotted budget. The advantages this system provides, however, led our team to believe we should pursue the design anyway. Having the system be vertically adjustable as well as horizontally allows it to be easily transported and moved. It will have the ability to fit through doorways and fit within a vehicle if need be. The system is also very safe due to its structurally supportive components and u-shaped design. Using metal for the majority of parts is going to make this device strong and long lasting under continual use.

5.2 Pugh Matrices

The following sections outline the matrices used to narrow down the concepts to one ground supported system and one overhead system. Our team decided to decide on one of each type of system due to not knowing if our client will be relocating in the future.

5.2.1 Ground Supported Systems

The figure shown below displays the Pugh matrix for our ground supported design concepts. The datum for the matrix is the semi circle base for which all other designs were correlated against on a plus, same, or minus scale. If the design got a plus, then that design performs better in that category than the datum. If it got a same, then it performed the same in that category. If the design got a minus, then the design performs worse than the datum design. The top three designs that rated the highest are Frame 1, Frame 2, and the Vehicle Suspension. These designs were then put into a decision matrix to obtain the best design.

Pugh Matrix (Ground Supported)												
<div style="border: 1px solid black; padding: 5px; width: fit-content;"> Concept Selection Legend Better + Same S Worse - </div>		Importance Rating Benchmark Option	Solution Alternatives									
			Frame 1	Frame 2	Hanging Fruit	Mobile Crane	Vehicle Suspension	Adjustable Ground Support	Frame 3	Weighted Ground Support	Semicircle Base	Ant-Inspired
Key Criteria												
Safety	4		+	+	+	+	+	+	+	-	D	-
Treadmill Compatable	4		S	+	S	S	S	S	S	S		S
Must Move 5 Meters	4		S	S	S	S	S	S	S	S		S
Easy to Operate	4		S	S	-	S	+	S	+	S	A	S
Cost to Build	3		-	-	-	-	-	-	-	-		-
Non-Obstructive/Low Profile	3		+	+	+	+	+	-	-	-		-
Unweighted System	3		S	S	S	+	+	S	-	-	T	S
Comfortability	3		S	S	S	S	S	S	S	S		S
Minimal Maintenance	3		-	-	-	-	-	-	S	S		S
Reliability	3		S	S	+	+	S	S	S	S	U	S
Adjustability	3		+	+	+	+	+	+	S	S		-
Non-Reflective	2		S	S	S	S	S	S	S	S		S
Durability	2		S	S	-	-	S	S	S	S	M	S
Sum of Positives			3	4	4	5	5	2	2	0	0	0
Sum of Negatives			2	2	4	3	2	3	3	4	0	4
Sum of Sames			8	7	5	5	6	8	8	9	0	9
Totals			9	9	5	7	9	7	7	5	0	5

Figure 21: Ground Support Pugh Matrix

5.2.2 Overhead Systems

The Pugh matrix for the overhead support systems is shown below in Figure 22. The datum of the matrix is the Bridge Concept. The other six designs were rated based off this design on a plus, same, or minus scale. The top three overhead support systems from the Pugh matrix are Track 2, Mobile Overhead Arches, and Triangle Beam. These three designs were then put into a decision matrix to determine the best overall overhead system.

Pugh Matrix (Overhead Support)								
<div style="border: 1px solid black; padding: 5px; width: fit-content;"> Concept Selection Legend Better + Same S Worse - </div>	Importance Rating	Benchmark Option	Solution Alternatives					
			Track 1	Track 2	Stage Truss Track	Bridge Concept	X-Y Track	Mobile Overhead Arches
Key Criteria								
Safety			-	+	+	D	-	S
Treadmill Compatable			S	S	S		S	S
Must Move 5 Meters			S	S	S		S	S
Easy to Operate			S	S	-	A	-	+
Cost to Build			+	+	-		-	+
Non-Obstructive/Low Profile			-	+	+		+	S
Unweighted System			S	S	S	T	S	S
Comfortability			S	S	S		S	S
Minimal Maintenance			+	+	-		-	+
Reliability			-	S	+	U	+	+
Adjustability			+	+	+		+	-
Non-Reflective			S	S	S		S	S
Durability			S	+	-	M	-	S
Sum of Positives			3	6	4	0	3	5
Sum of Negatives			3	0	4	0	5	1
Sum of Sames			7	7	5	0	5	7
TOTALS			7	13	5	0	3	11

Figure 22: Overhead Support Pugh Matrix

5.3 Decision Matrices

With our top three design concepts generated from our Pugh Carts our team then conducted a decision matrix to clarify the top design for both the ground supported (Figure 23) and overhead track systems (Figure 24). To construct a decision matrix our team took our customer requirements and ranked them against each of the concepts from 1-100. A score of 100 means that the concept perfectly supports the requirements and a score of 1 means that the concept does not support the requirement. Weights of importance relating to the customer requirements were then generated to multiply by the rankings. The final weighted scores were the determining factors in which design we selected to pursue for our project. To make the matrices easier to follow our team color coordinated the answers. Green means that the concept ranked high in its ability to work with the customer requirements and red means the concept did not rank well regarding the requirements. For the ground-supported system, our top ranked design concept was Frame Design 2: Ground Supported Mobile Frame Type 2. For the overhead track system, our top ranked design concept was Track 2: Column Supported Overhead Track System.

Decision Factors		Vehicle Suspension		Frame 2		Frame 1	
Criteria	Wt.	1	2	3	4	5	6
Safety	0.10	75	7.3	95	9.3	95	9.3
Treadmill Compatible	0.10	100	9.8	100	9.8	100	9.8
Must Move 5 meters	0.10	100	9.8	100	9.8	100	9.8
Easy to Operate	0.10	85	8.3	95	9.3	95	9.3
Cost to Build	0.07	90	8.8	95	9.3	85	8.3
Non-Obstructive/Low Profile	0.07	95	9.3	95	9.3	85	8.3
Un-weighted System (Zero Tensions)	0.07	100	9.8	87	8.5	87	8.5
Comfortability	0.07	80	7.8	87	8.5	80	7.8
Minimal Maintenance	0.07	75	7.3	90	8.8	90	8.8
Reliability	0.07	78	7.6	90	8.8	90	8.8
Adjustability	0.07	70	6.8	100	9.8	90	8.8
Non-Reflective	0.05	100	9.8	100	9.8	100	9.8
Durability	0.05	80	7.8	90	8.8	90	8.8
Weighted Scores		8.5		9.2		8.9	

Figure 23: Ground Supported Decision Matrix

Decision Factors		Triangle beam		Track 2		Tunnel System	
Criteria	Wt.	1	2	3	4	5	6
Safety	0.10	80	7.8	92	9	90	8.8
Treadmill Compatible	0.10	100	9.8	100	9.8	100	9.8
Must Move 5 meters	0.10	100	9.8	100	9.8	100	9.8
Easy to Operate	0.10	90	8.8	95	9.3	95	9.3
Cost to Build	0.07	90	8.8	70	6.8	80	7.8
Non-Obstructive/Low Profile	0.07	85	8.3	100	9.8	89	8.7
Un-weighted System (Zero Tensions)	0.07	90	8.8	85	8.3	85	8.3
Comfortability	0.07	95	9.3	93	9.1	93	9.1
Minimal Maintenance	0.07	95	9.3	95	9.3	95	9.3
Reliability	0.07	80	7.8	90	8.8	83	8.1
Adjustability	0.07	90	8.8	85	8.3	90	8.8
Non-Reflective	0.05	100	9.8	100	9.8	100	9.8
Durability	0.05	85	8.3	95	9.3	90	8.8
Weighted Scores		8.10		8.15		8.10	

COLOR KEY	
	HIGH SCORE
	AVERAGE SCORE
	LOW SCORE

Figure 24: Overhead System Decision Matrix

REFERENCES

- [1] Biodex Medical Systems, "Nx Step Unweighing System," in *Senior Rehab Balance and Mobility*. [Online]. Available: <http://www.biodexseniorrehab.com/products/unweighing-system/index.html>. Accessed: Feb. 16, 2017.
- [2] S. Inc, "Ceiling-Mounted Track System," in *Solo-Step*, LisixMedia, 2016. [Online]. Available: <http://solostep.com/products/ceiling-mounted-track-system/>. Accessed: Feb. 16, 2017.
- [3] Aretech LLC, "ZeroG Gait and Balance Rehabilitation," in *Aretechllc*, Aretech, 2016. [Online]. Available: <http://www.aretechllc.com>. Accessed: Feb. 16, 2017.
- [4] B. Inc, "The Vector Advantage," in *Bioness Vector*, 2015. [Online]. Available: <http://bionessvector.com/vector>. Accessed: Feb. 16, 2017.
- [5] S. McMannis, "Balance Mobility and Gait Training," in *Safe Gait Solutions: Innovation for Rehabilitation*, SafeGait, 2016. [Online]. Available: <http://safegait.com/>. Accessed: Feb. 17, 2017.
- [6] "How Seatbelts Work," HowStuffWorks, 09-Apr-2002. [Online]. Available: <http://auto.howstuffworks.com/car-driving-safety/safety-regulatory-devices/seatbelt3.htm>. [Accessed: 23-Mar-2017].
- [7] "How Car Suspensions Work," HowStuffWorks, 11-May-2005. [Online]. Available: <http://auto.howstuffworks.com/car-suspension2.htm>. [Accessed: 23-Mar-2017].
- [8] E. Group, "Endurance Technologies," Endurance Technologies. [Online]. Available: <https://www.endurancegroup.com/products/suspension/shock-absorbers>. [Accessed: 23-Mar-2017].
- [9] D. Kutula, "Roughneck Manual Geared Trolley," in *Northern Tools + Equipment*, 2016. [Online]. Available: http://www.northerntool.com/shop/tools/product_200485276_200485276. Accessed: Feb. 17, 2017.
- [10] "Motorized Trolleys (MT series)," in *ACI Hoist and Crane*, American Crane, 2016. [Online]. Available: <http://americancrane.biz/motorizedtrolley.html>. Accessed: Feb. 17, 2017.
- [11] Columbus McKinnon Corporation, "PT Trolley," in *Chester Hoist*. [Online]. Available: <http://www.chesterhoist.com/products/trolleys/ptrolley.aspx>. Accessed: Feb. 17, 2017.
- [12] Rollon, "Linear Rail Systems," in *Rollon Linear Evolution*, 2017. [Online]. Available: <http://www.rollon.com/US/en/products/linear-line/1-compact-rail/#product-description>. Accessed: Feb. 16, 2017.

- [13] W. Steel, "Shopping For the Right Steel Beams," 2012. [Online]. Available: <http://wasatchsteel.blogspot.com/2014/03/shopping-for-right-steel-beams.html>. Accessed: Feb. 17, 2017.
- [14] Real Carriage Door Co., "Box Rail Sliding Hardware," in *REAL Sliding Hardware*, Real Sliding Hardware, 2017. [Online]. Available: <https://www.realslidinghardware.com/box-rail-sliding-hardware-kit/>. Accessed: Feb. 17, 2017.
- [15] S. M. Co, "Stanley Hardware: Box Rail," in *Stanley Hardware*, 2016. [Online]. Available: <http://www.stanleyhardware.com/type/box-rail-box-rail>. Accessed: Feb. 17, 2017.
- [16] "Double Braid Nylon Rope," in *Knot and Rope Supply*, 2017. [Online]. Available: <http://www.knotandrope.com/store/pc/Double-Braid-Nylon-Rope-c22.htm>. Accessed: Feb. 17, 2017.
- [17] "5/16 inch, 7 x 19 Grade 304 Vinyl Coated Stainless Steel Cable," in *E-Rigging*, 2017. [Online]. Available: <http://www.e-rigging.com/5-16-vinyl-coated-stainless-steel-cable>. Accessed: Feb. 17, 2017.
- [18] "Synthetic Textile Industries Antenna Support Rope," in *DX Engineering*, DX Engineering, 2017. [Online]. Available: https://www.dxengineering.com/parts/syn-dbr-312-100?seid=dxese1&cm_mmc=pla-google-_-shopping-_-dxese1-_-synthetic-textile-industries&gclid=CM7-hqvnI9ICFdRyfgodigkKXw. Accessed: Feb. 17, 2017.

APPENDIX A: House of Quality

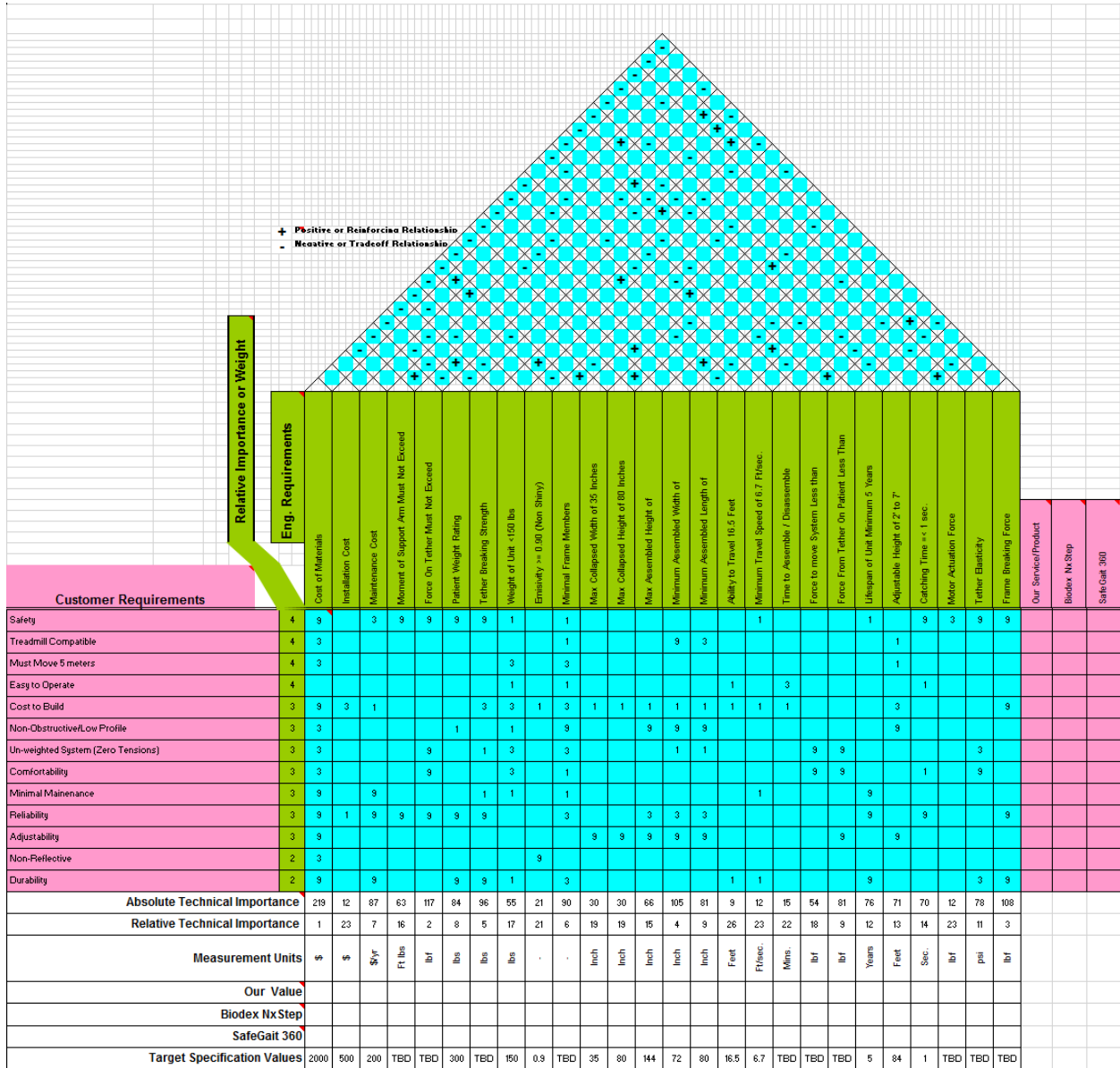

Figure 25: House of Quality

APPENDIX B: Designs Considered

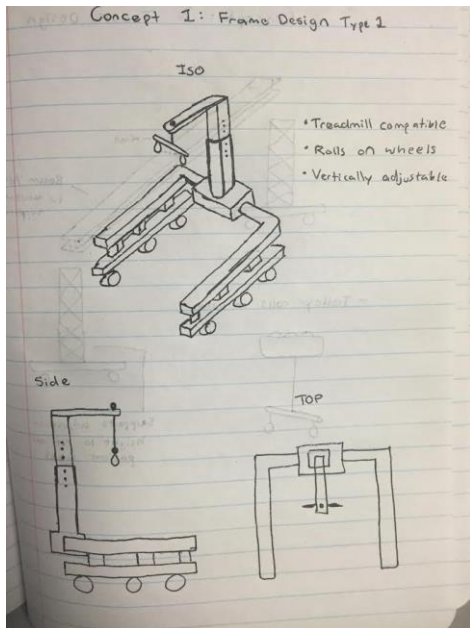

Figure 26: Ground Supported Mobile Frame

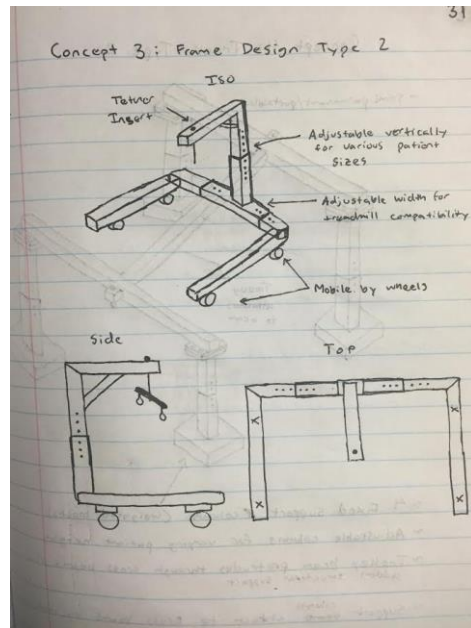

Figure 27: Ground Supported Mobile Frame Type 2

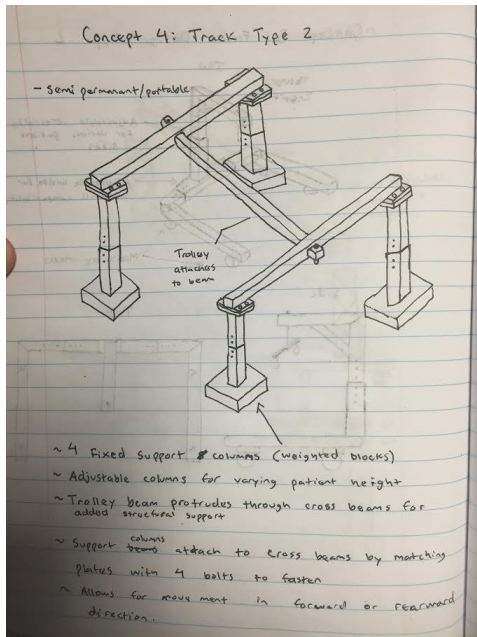

Figure 28: Column Supported Overhead Track System

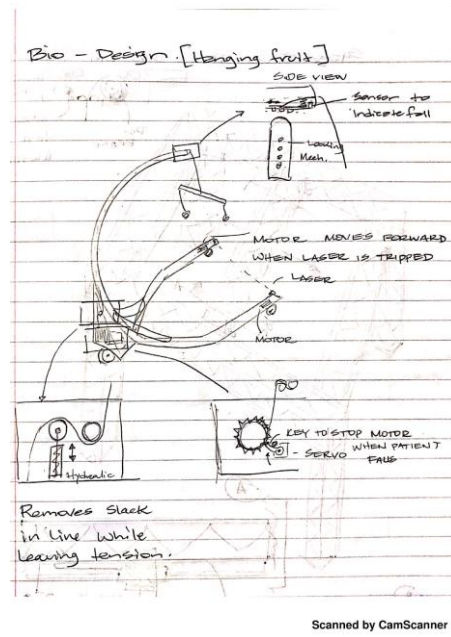
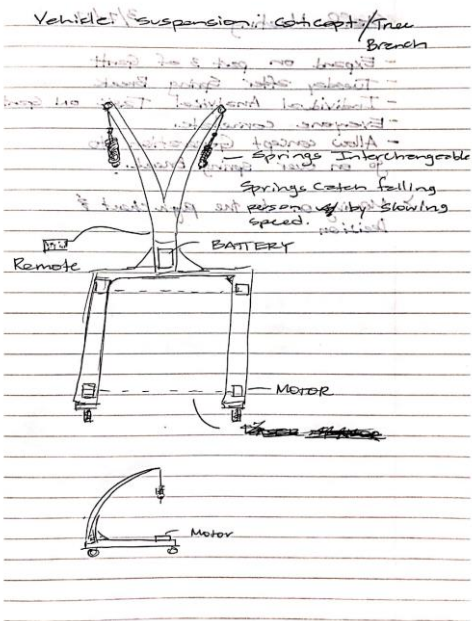
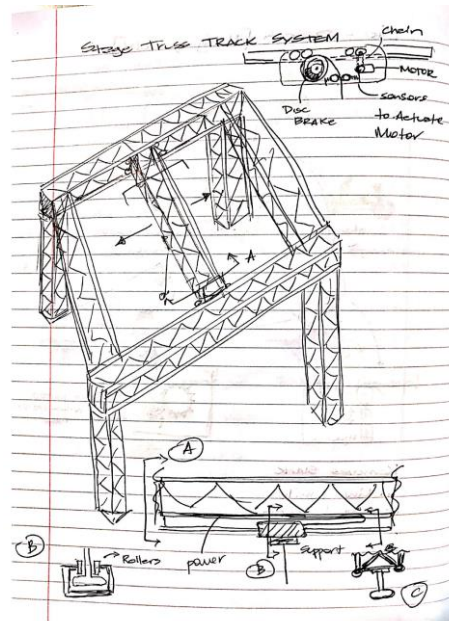

Figure 29: Hanging Fruit



Scanned by CamScanner

Figure 30: Vehicle Suspension



Scanned by CamScanner

Figure 31: Stage Truss Track System

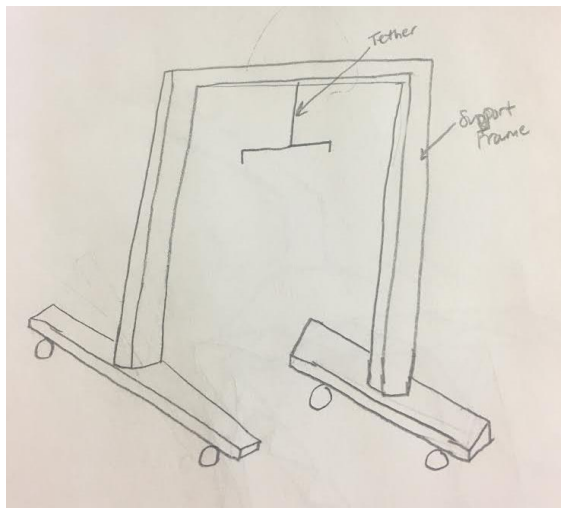

Figure 32: Frame Ground Support

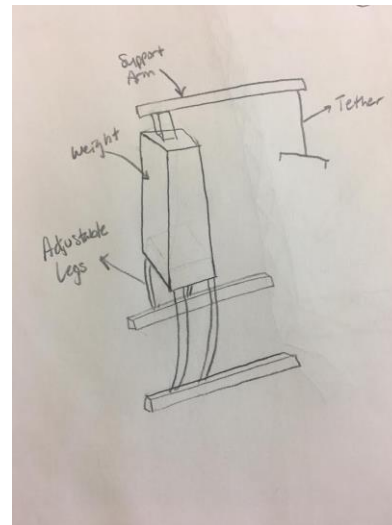

Figure 33: Adjustable Ground Support

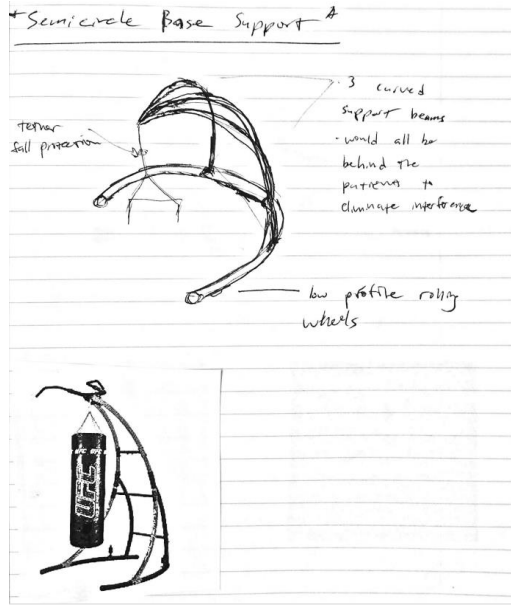

Figure 34: Semicircle Base Support

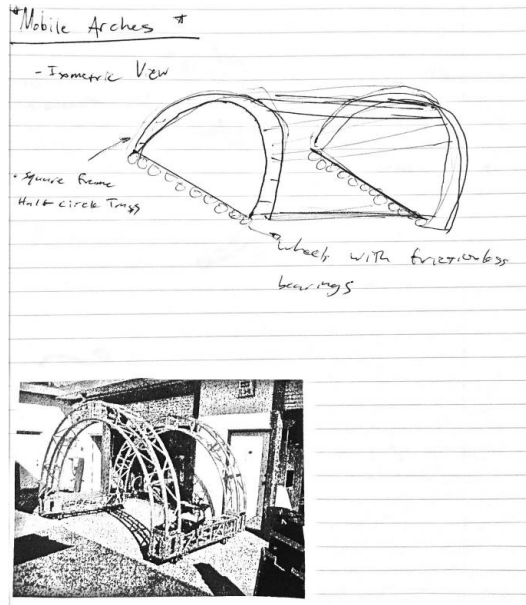

Figure 35: Mobile Arches

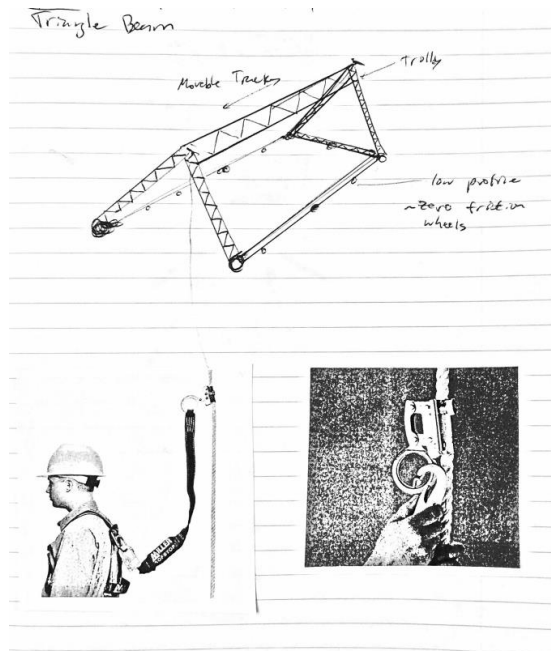

Figure 36: Triangle Beam